Very low offset single bipolar operational amplifier

Features

- Extremely low offset: 150 μ V/ max.
- Low input bias current: 1.8nA
- LOW V_{i0} drift: 0.5 μ V/ $^{\circ}$ C
- Ultra stable with time: 2 μ V/month max.
- Wide supply voltage range: \pm 3V to \pm 22V
- Temperature range: 0 $^{\circ}$ C to -105 $^{\circ}$ C

Description

The OP07 is a very high precision op-amp with an offset voltage maximum of 150 μ V.

Offering also low input current (1.8nA) and high gain (400V/mV), the OP07C is particularly suitable for instrumentation applications.

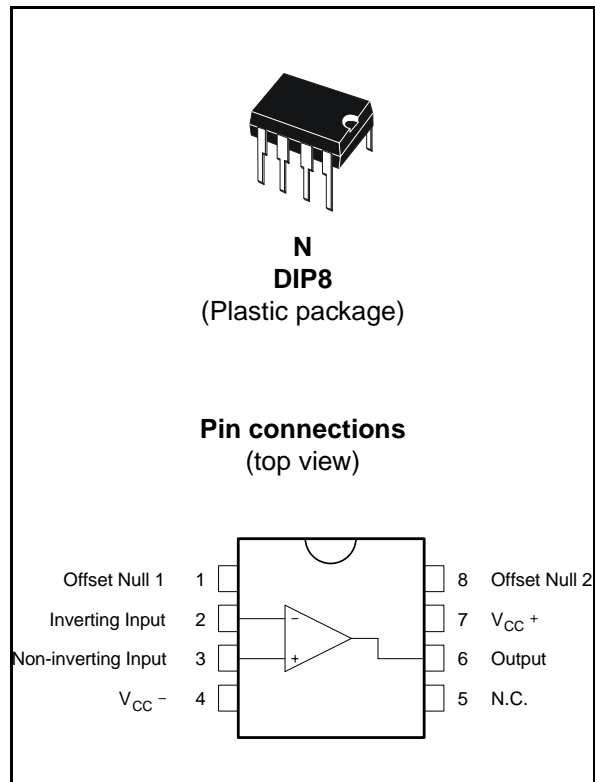

1 Schematic diagram

Figure 1. Schematic diagram

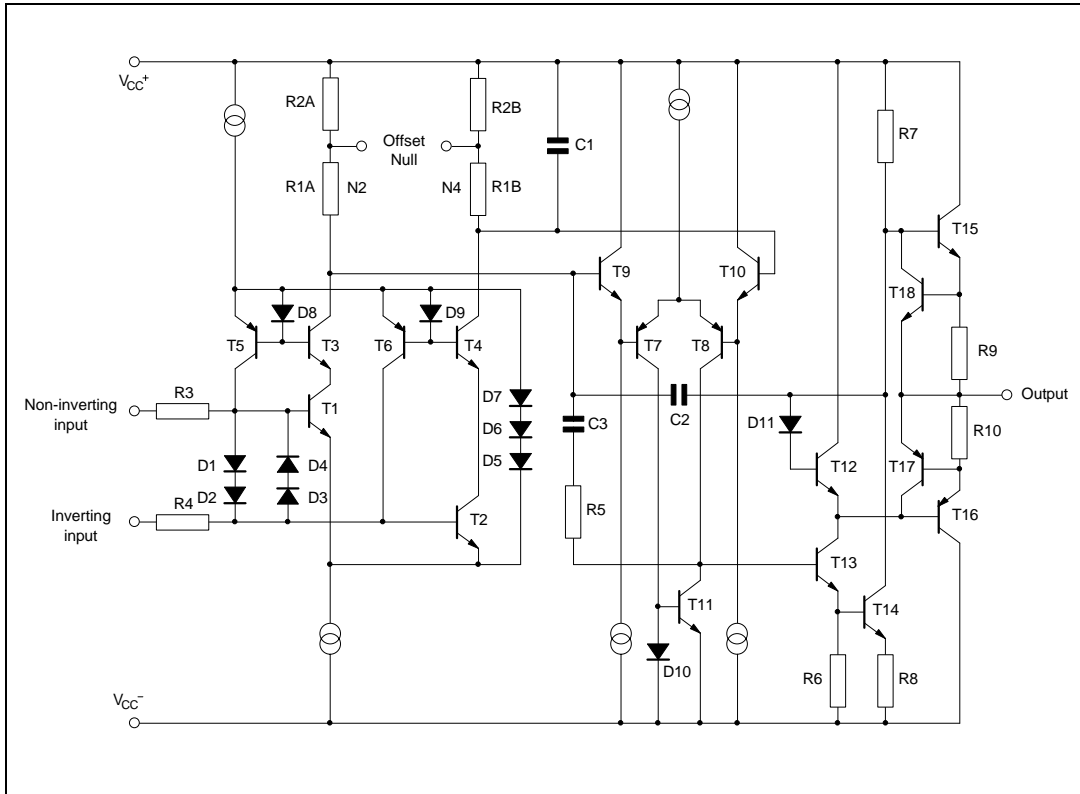
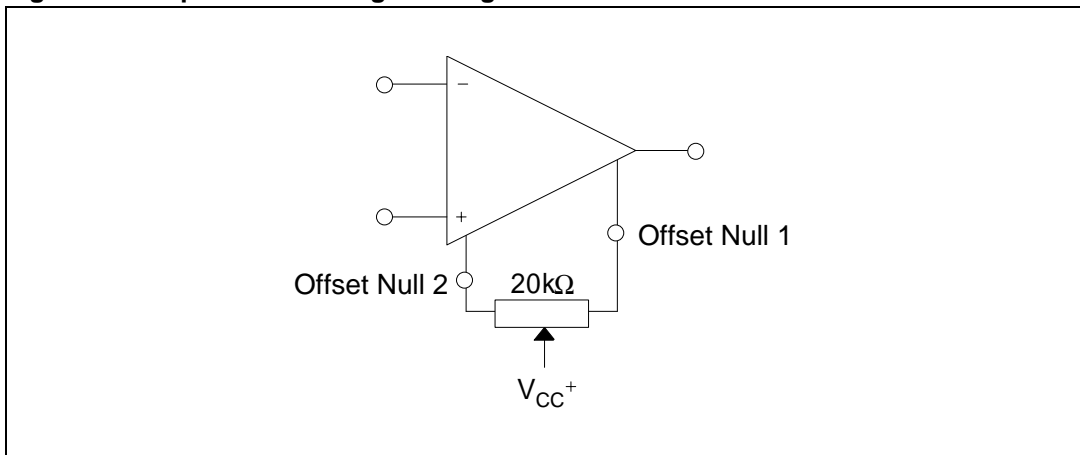

Figure 2. Input offset voltage nulling circuit



2 Absolute maximum ratings

Table 1. Absolute maximum ratings

Symbol	Parameter	Value	Unit
V_{CC}	Supply voltage	± 22	V
V_{id}	Differential input voltage	± 30	V
V_i	Input voltage	± 22	V
T_{oper}	Operating temperature	-40 to 105	°C
T_{stg}	Storage temperature	-65 to 150	°C
R_{thja}	Thermal resistance junction to ambient ^{(1) (2)} DIP8	85	°C/W
R_{thjc}	Thermal resistance junction to case ^{(1) (2)} DIP8	41	°C/W
ESD	HBM: human body model ⁽³⁾	1.5	kV
	MM: machine model ⁽⁴⁾	200	V
	CDM: charged device model ⁽⁵⁾	1.5	kV

- Short-circuits can cause excessive heating and destructive dissipation.
- R_{th} are typical values.
- Human body model: 100pF discharged through a 1.5k Ω resistor between two pins of the device, done for all couples of pin combinations with other pins floating.
- Machine model: a 200pF cap is charged to the specified voltage, then discharged directly between two pins of the device with no external series resistor (internal resistor < 5 Ω). Done for all couples of pin combinations with other pins floating.
- Charged device model: all pins plus package are charged together to the specified voltage and then discharged directly to the ground.

3 Electrical characteristics

Table 2. $V_{CC^+} = 15\text{ V}$, $V_{CC^-} = \text{Ground}$, $T_{\text{amb}} = 25^\circ\text{ C}$ (unless otherwise specified)

Symbol	Parameter	Min.	Typ.	Max.	Unit
V_{io}	Input offset voltage $0^\circ\text{C} \leq T_{\text{amb}} \leq +105^\circ\text{C}$		60	150 250	μV
	Long term input offset - voltage stability ⁽¹⁾		0.4	2	$\mu\text{V}/\text{Mo}$
DV_{io}	Input offset voltage drift		0.5	1.8	$\mu\text{V}/^\circ\text{C}$
I_{io}	Input offset current ($V_{ic} = 0\text{V}$) $0^\circ\text{C} \leq T_{\text{amb}} \leq +105^\circ\text{C}$		0.8	6 7	nA
DI_{io}	Input offset current drift		15	50	$\text{pA}/^\circ\text{C}$
DI_{ib}	Input bias current drift		15	50	$\text{pA}/^\circ\text{C}$
R_o	Open loop output resistance		60		Ω
R_{id}	Differential input resistance		33		M Ω
R_{ic}	Common mode input resistance		120		G Ω
V_{icm}	Input common mode voltage range $0^\circ\text{C} \leq T_{\text{amb}} \leq +105^\circ\text{C}$	± 13 ± 13	± 13.5		V
CMR	Common-mode rejection ratio ($V_{ic} = V_{icm - \text{min}}$) $0^\circ\text{C} \leq T_{\text{amb}} \leq +105^\circ\text{C}$	100 97	120		dB
SVR	Supply voltage rejection ratio ($V_{CC} = \pm 3$ to $\pm 18\text{V}$) $0^\circ\text{C} \leq T_{\text{amb}} \leq +105^\circ\text{C}$	90 86	104		dB
A_{vd}	Large signal voltage gain $V_{CC} = \pm 15$, $R_L = 2\text{k}\Omega$, $V_o = \pm 10\text{V}$ $0^\circ\text{C} \leq T_{\text{amb}} \leq +105^\circ\text{C}$ $V_{CC} = \pm 3$, $R_L = 500\Omega$, $V_o = \pm 0.5\text{V}$	120 100 100	400 400		V/mV
V_{opp}	Output voltage swing $R_L = 10\text{k}\Omega$ $R_L = 2\text{k}\Omega$ $R_L = 1\text{k}\Omega$ $0^\circ\text{C} \leq T_{\text{amb}} \leq +105^\circ\text{C}$ $R_L = 2\text{k}\Omega$	± 12 ± 11.5 ± 11	± 13 ± 12.8 ± 12		V
SR	Slew rate ($R_L = 2\text{k}\Omega$, $C_L = 100\text{pF}$)		0.17		V/ μs
GBP	Gain bandwidth product ($R_L = 2\text{k}\Omega$, $C_L = 100\text{pF}$, $f = 100\text{kHz}$)		0.5		MHz
I_{CC}	Supply current - no load $0^\circ\text{C} \leq T_{\text{amb}} \leq +105^\circ\text{C}$ $V_{CC} = \pm 3\text{V}$		2.7 0.67	5 6 1.3	mA

Table 2. $V_{CC^+} = 15\text{ V}$, $V_{CC^-} = \text{Ground}$, $T_{\text{amb}} = 25^\circ\text{ C}$ (unless otherwise specified) (continued)

Symbol	Parameter	Min.	Typ.	Max.	Unit
e_n	Equivalent input noise voltage f = 10Hz f = 100Hz f = 1kHz		11 10.5 10	20 13.5 11.5	$\frac{\text{nV}}{\sqrt{\text{Hz}}}$
i_n	Equivalent input noise current f = 10Hz f = 100Hz f = 1kHz		0.3 0.2 0.1	0.9 0.3 0.2	$\frac{\text{pA}}{\sqrt{\text{Hz}}}$

1. Long term input offset voltage stability refers to the average trend line of V_{io} vs time over extended periods after the first 30 days of operation.

4 Package information

In order to meet environmental requirements, ST offers these devices in ECOPACK® packages. These packages have a lead-free second level interconnect. The category of second level interconnect is marked on the package and on the inner box label, in compliance with JEDEC Standard JESD97. The maximum ratings related to soldering conditions are also marked on the inner box label. ECOPACK is an ST trademark. ECOPACK specifications are available at: www.st.com.

Figure 3. DIP8 package mechanical data

Ref.	Dimensions					
	Millimeters			Inches		
	Min.	Typ.	Max.	Min.	Typ.	Max.
A			5.33			0.210
A1	0.38			0.015		
A2	2.92	3.30	4.95	0.115	0.130	0.195
b	0.36	0.46	0.56	0.014	0.018	0.022
b2	1.14	1.52	1.78	0.045	0.060	0.070
c	0.20	0.25	0.36	0.008	0.010	0.014
D	9.02	9.27	10.16	0.355	0.365	0.400
E	7.62	7.87	8.26	0.300	0.310	0.325
E1	6.10	6.35	7.11	0.240	0.250	0.280
e		2.54			0.100	
eA		7.62			0.300	
eB			10.92			0.430
L	2.92	3.30	3.81	0.115	0.130	0.150

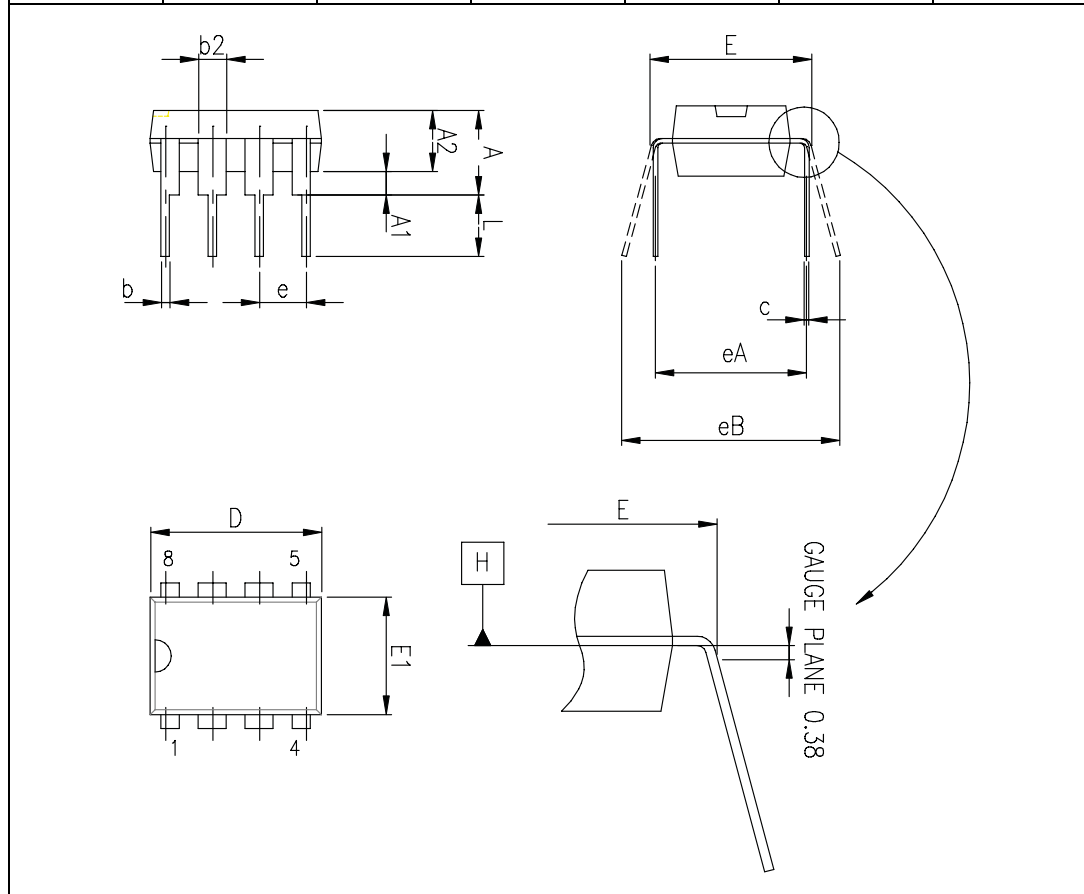

5 Ordering information

Table 3. Order codes

Part number	Temperature range	Package	Packing	Marking
OP07C OP07CN	0°C, +105°C	DIP8	Tube	OP07CN

6 Revision history

Table 4. Document revision history

Date	Revision	Changes
20-May-2003	1	Initial release.
23-Jul-2007	2	Format update. R_{thja} , R_{thjc} , and ESD values added in Table 1: Absolute maximum ratings . Temperature range modified to 0-105°C.

Please Read Carefully:

Information in this document is provided solely in connection with ST products. STMicroelectronics NV and its subsidiaries ("ST") reserve the right to make changes, corrections, modifications or improvements, to this document, and the products and services described herein at any time, without notice.

All ST products are sold pursuant to ST's terms and conditions of sale.

Purchasers are solely responsible for the choice, selection and use of the ST products and services described herein, and ST assumes no liability whatsoever relating to the choice, selection or use of the ST products and services described herein.

No license, express or implied, by estoppel or otherwise, to any intellectual property rights is granted under this document. If any part of this document refers to any third party products or services it shall not be deemed a license grant by ST for the use of such third party products or services, or any intellectual property contained therein or considered as a warranty covering the use in any manner whatsoever of such third party products or services or any intellectual property contained therein.

UNLESS OTHERWISE SET FORTH IN ST'S TERMS AND CONDITIONS OF SALE ST DISCLAIMS ANY EXPRESS OR IMPLIED WARRANTY WITH RESPECT TO THE USE AND/OR SALE OF ST PRODUCTS INCLUDING WITHOUT LIMITATION IMPLIED WARRANTIES OF MERCHANTABILITY, FITNESS FOR A PARTICULAR PURPOSE (AND THEIR EQUIVALENTS UNDER THE LAWS OF ANY JURISDICTION), OR INFRINGEMENT OF ANY PATENT, COPYRIGHT OR OTHER INTELLECTUAL PROPERTY RIGHT.

UNLESS EXPRESSLY APPROVED IN WRITING BY AN AUTHORIZED ST REPRESENTATIVE, ST PRODUCTS ARE NOT RECOMMENDED, AUTHORIZED OR WARRANTED FOR USE IN MILITARY, AIR CRAFT, SPACE, LIFE SAVING, OR LIFE SUSTAINING APPLICATIONS, NOR IN PRODUCTS OR SYSTEMS WHERE FAILURE OR MALFUNCTION MAY RESULT IN PERSONAL INJURY, DEATH, OR SEVERE PROPERTY OR ENVIRONMENTAL DAMAGE. ST PRODUCTS WHICH ARE NOT SPECIFIED AS "AUTOMOTIVE GRADE" MAY ONLY BE USED IN AUTOMOTIVE APPLICATIONS AT USER'S OWN RISK.

Resale of ST products with provisions different from the statements and/or technical features set forth in this document shall immediately void any warranty granted by ST for the ST product or service described herein and shall not create or extend in any manner whatsoever, any liability of ST.

ST and the ST logo are trademarks or registered trademarks of ST in various countries.

Information in this document supersedes and replaces all information previously supplied.

The ST logo is a registered trademark of STMicroelectronics. All other names are the property of their respective owners.

© 2007 STMicroelectronics - All rights reserved

STMicroelectronics group of companies

Australia - Belgium - Brazil - Canada - China - Czech Republic - Finland - France - Germany - Hong Kong - India - Israel - Italy - Japan - Malaysia - Malta - Morocco - Singapore - Spain - Sweden - Switzerland - United Kingdom - United States of America

www.st.com